

WT-DMX-S

DMX512

WiFi & RF 5 in 1 DMX512 Master

- 1-5 color WiFi-DMX master, output 1-5 channel DMX signal, comply with the DMX512 standard protocols.
8-bit (256 levels) / 16-bit (65536 levels) grey level selectable.
- Tuya APP cloud control, support on/off, RGB color, color temperature and brightness adjust, delay turn on/off light, timer run, static or dynamic scene edit and recall, music play function.
- Voice control, support Amazon Alexa, Google Assistant, Tmall Genie, Xiaodu voice assistant.
- Connect with external two push switch to achive on/off, brightness adjustment, scene switching.
- Match with RF 2.4G remote optional.
- User need set light type by press set key before Tuya APP network connection and match RF remote of the same light type.
- Each WT-DMX-S controller can work as WiFi/RF-DMX512 converter, then use Tuya APP to control one or more DMX512 decoders for synchronized control over long distances.

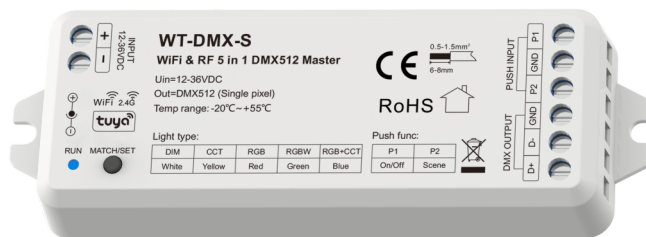

CE RoHS emc RED

Technical Parameters

Input and Output		Dimming data		Safety and EMC	
Input voltage	12-36VDC	Input signal	WiFi + RF 2.4G + Push switch	EMC standard (EMC)	ETSI EN 301 489-1 V2.2.3 ETSI EN 301 489-17 V3.2.4
Input current	< 0.1A	Control distance	30m(Barrier-free space)	Radio Equipment (RED)	ETSI EN 300 328 V2.2.2
Output signal	DMX512(1-5 Channel)	Dimming gray scale	256 or 65536 level	Certification	CE, EMC, RED
Warranty		Package		Environment	
Warranty	5 years	Size	L120 x W43 x H27mm	Operation temperature	Ta: -20°C ~ +55°C
Protection	Reverse polarity	Gross weight	0.055kg	Case temperature (Max.)	Tc: +65°C

Mechanical Structures and Installations

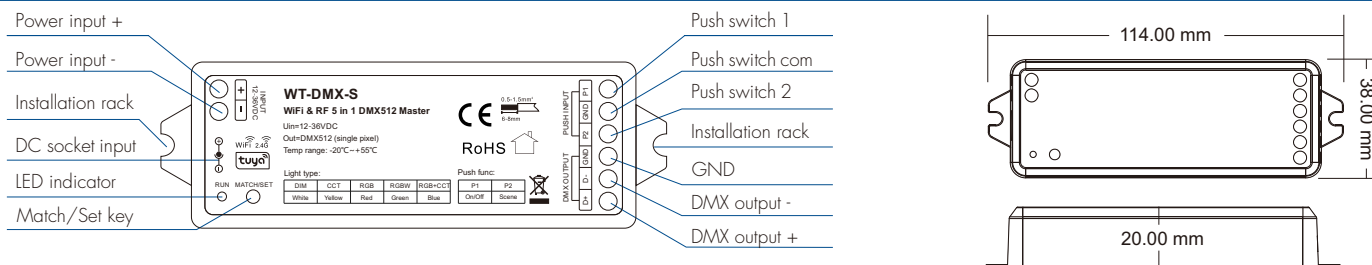

System wiring

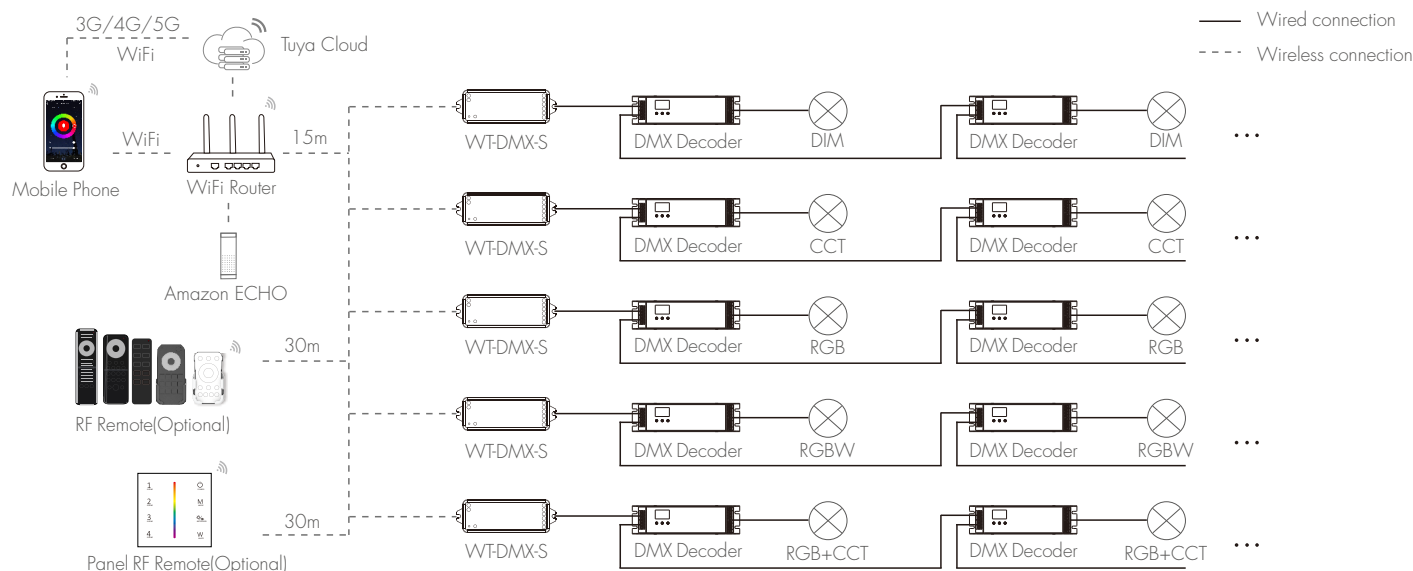

- Note:
1. The above distance is measured in spacious (no obstacle) environment, Please refer to the actual test distance before installation.
 2. Please check if the WiFi router net in 2.4G band, the 5G band is not available, and do not hide your router network.
 3. Please keep the distance between WT-DMX-S devices and router close, and check the WiFi signals.

Take connecting multiple four-channel constant voltage DMX512 decoders to synchronously control multiple RGBW light strips as an example:

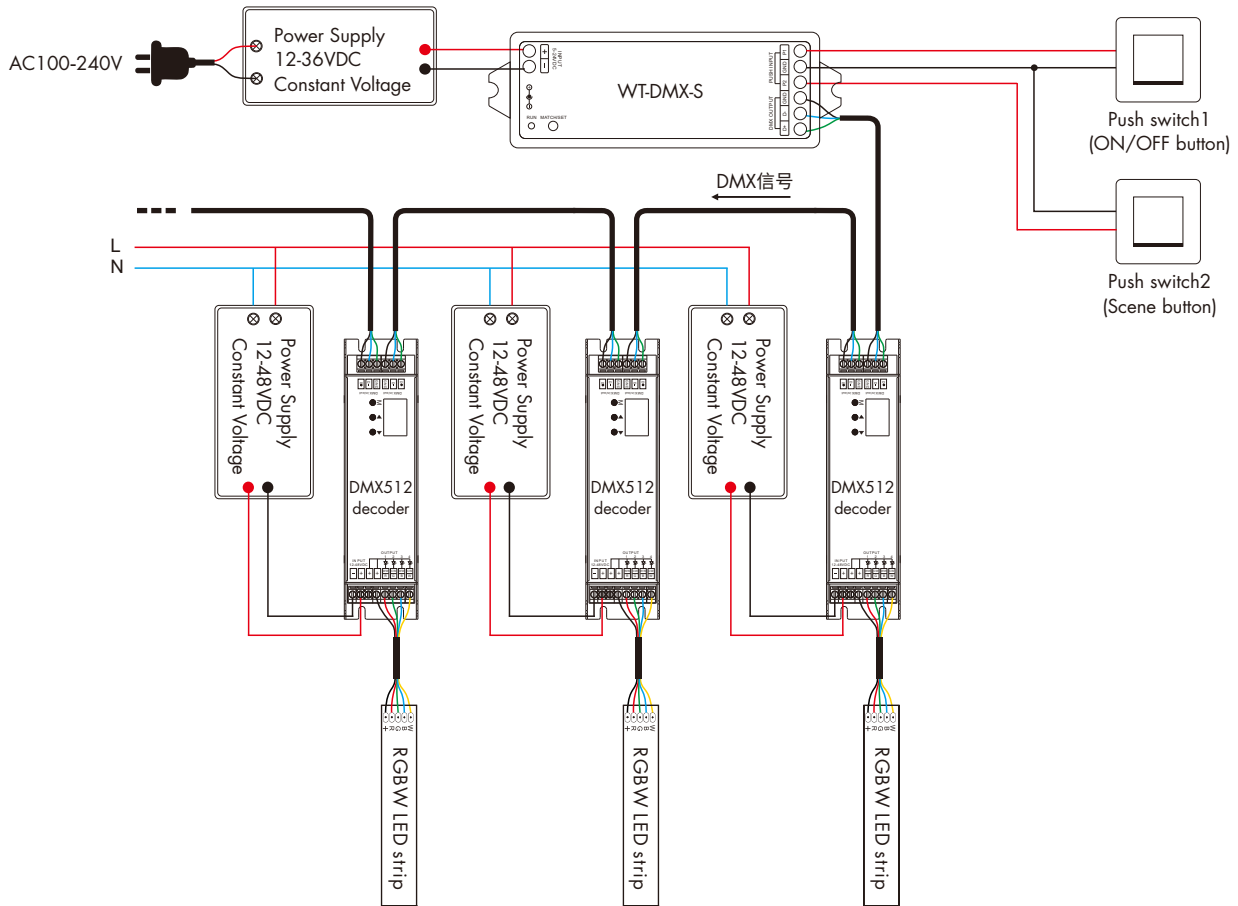

- Note:**
- DMX512 master and DMX512 decoder need to be powered by a separate power supply.
 - Light type setting: Long press the Match/Set key for 2s to sequentially switch five light types: DIM, CCT, RGB, RGBW, RGB+CCT. RUN indicator color (white: DIM, yellow: CCT, red: RGB, green: RGBW, blue: RGB+CCT). When the RUN indicator to change to the color that corresponds to the light type, release, then do smart config by tuya APP, or short press Match/Set key to match with RF remote.
 - Factory default: RGBW light type, 8-bit grey output. Long press Match/Set key for 15s to restore the factory default parameter settings. Long press Match/Set key for 20s to set to 16-bit grey output. When running a slow dynamic gradient effect, the recommended setting is 16-bit grey output. When setting to 16-bit grey output, note that the DMX512 decoder should be set to 16-bit decoding mode.
 - An DMX signal amplifier is needed if more than 32 DMX512 decoders are connected, or use overlong signal line, signal amplification should not be more than 5 times continuously.
 - If the recoil effect occurs because of longer signal line or bad line quality, please try to connect 0.25W 90-120Ω terminal resistor at the end of each DMX signal line.

DMX channel address assignment

For different light type, the correspondence of each channel address of the DMX master is as follows:

8-bit grey output:

light type	DIM	CCT		RGB			RGBW				RGB+CCT				
		WW	CW	R	G	B	R	G	B	W	R	G	B	WW	CW
DMX master address of each channel	1	1	2	1	2	3	1	2	3	4	1	2	3	4	5

16-bit grey output:

light type	DIM	CCT		RGB			RGBW				RGB+CCT				
		WW	CW	R	G	B	R	G	B	W	R	G	B	WW	CW
DMX master address of each channel	1-2	1-2	3-4	1-2	3-4	5-6	1-2	3-4	5-6	7-8	1-2	3-4	5-6	7-8	9-10

Note: even channel for micro dimming.

Please download the corresponding tuya/smart life app according to your region.

Press and hold Match/Set key for 2s, switch 5 kinds light type in sequence, notice this operation does not automatically clear previous network connection.

Press and hold Match/Set key for 5s, or push twice Match/Set key fastly, clear previous network connection, enter Smart config mode, the purple LED indicator flash fastly.

Repeat power on and off for 5 consecutive times, also clear previous network connection, enter Smart config mode.

In Tuya APP, automatically add devices, you can find RGBWW device (or other DIM, CCT, RGB or RGB+CCT).

If Tuya APP network connection succeed, the RUN LED indicator will stop flash purple, and turn corresponding light type color (White: DIM, Yellow: CCT, Red: RGB, Green: RGBW, Blue: RGB+CCT).



Smart life APP



Tuya Smart

Tuya APP interface

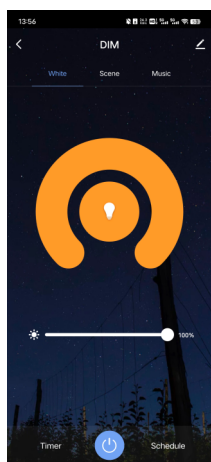

White interface

For DIM type:
Touch brightness slide to adjust brightness.

For RGB type:
Touch brightness slide, get RGB mixed white firstly, then to adjust white brightness.

For RGBW type:
Touch brightness slide, adjust white channel brightness.

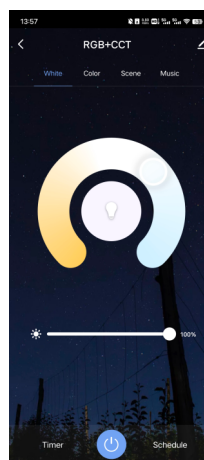

Color temperature interface

For CCT type:
Touch color wheel to adjust color temperature.
Touch brightness slide to adjust brightness.

For RGB+CCT type:
Touch color wheel to adjust color temperature, RGB will turn off automatically.
Touch brightness slide to adjust white brightness.

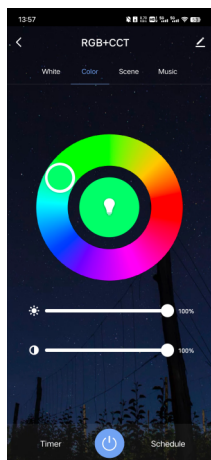

Colour interface

For RGB or RGBW type:
Touch color wheel to adjust static RGB color.
Touch brightness slide to adjust color brightness.
Touch saturation slide to adjust color saturation, namely gradient from the current color to white (RGB mixed).

For RGB+CCT type:
Touch color wheel to adjust static RGB color, WW/CW will turn off automatically.
Touch brightness slide to adjust color brightness.
Touch saturation slide to adjust color saturation, namely gradient from the current color to white (RGB mixed).

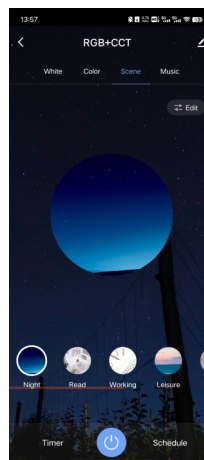

Scene interface

The 1-4 scene is static color for all light type. the inner color of these scene can be editable.

The 5-8 scene is dynamic mode for RGB, RGBW, RGB+CCT type, such as green fade in and fade out, RGB jump, 6 color jump, 6 color smooth.

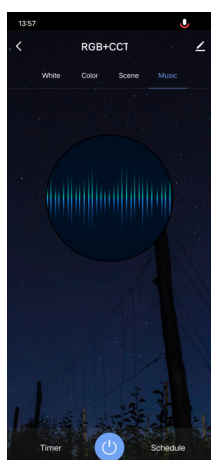

Music, Timer, Schedule

The music play can use smart phone music player or micro-phone as music signal input.

The Timer key can turn on or turn off light in the next 24 hours.

The Schedule key can add multiple timers to turn on or turn off light according to different time periods.

Push switch 1 (ON/OFF button)

Short press: Turn on/off the light.

Long press(1-6s): Step-less dimming, with every other long press, the light level goes to the opposite direction.

Push switch 2 (Scene button)

Short press: For DIM/CCT light type, sequential switching of the 4 scenes.

For RGB/RGBWW/RGB+CCT light type, sequential switching of the 8 scenes.

Long press(>2s): Recall scene 1.

Users can set static or dynamic scenes via Tuya Smart/Smart Life APP.

WT-DMX-S match RF remote control (Optional)

End user can choose the suitable match/delete ways. Two options are offered for selection:

Use the WT-DMX-S's Match/Set key

Match:

Short press match/set key of WT-DMX-S, immediately press on/off key (single zone remote) or zone key (multiple zone remote) on the remote. The LED indicator fast flash a few times means match is successful.

Delete:

Press and hold match/set key of WT-DMX-S for 10s, The LED indicator fast flash a few times means all matched remotes were deleted.

Use Power Restart

Match:

Switch off the power of WT-DMX-S, then switch on power, repeat again. Immediately short press on/off key (single zone remote) or zone key (multiple zone remote) 3 times on the remote. The light blinks 3 times means match is successful.

Delete:

Switch off the power of WT-DMX-S, then switch on power, repeat again. Immediately short press on/off key (single zone remote) or zone key (multiple zone remote) 5 times on the remote. The light blinks 5 times means all matched remotes were deleted.

Default dynamic change mode (RF remote control call-out)

For RGB/RGBW:

No.	Name	No.	Name
1	RGB jump	6	RGB fade in and out
2	RGB smooth	7	Red fade in and out
3	6 color jump	8	Green fade in and out
4	6 color smooth	9	Blue fade in and out
5	Yellow cyan purple smooth	10	White fade in and out

For RGB+CCT:

No.	Name	No.	Name
1	RGB jump	6	RGB fade in and out
2	RGB smooth	7	Red fade in and out
3	6 color jump	8	Green fade in and out
4	6 color smooth	9	Blue fade in and out
5	Color temperature smooth	10	White fade in and out