

# DA-ML(WT)

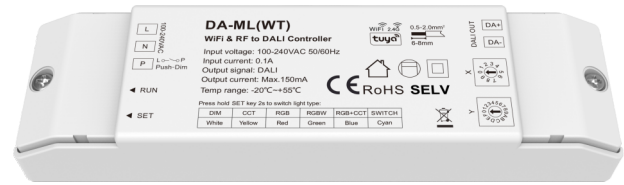

## WiFi & RF DALI Dimmer

- WiFi & RF signal input, DALI signal output.
- Can be used as a DALI bus power supply.
- 1 DALI address, support DT6 dimming, DT8-TC color temperature, DT8-RGB, DT8-RGBW or DT7 switch.
- Tuya smart APP cloud control, support on/off, RGB color, color temperature and brightness adjust, delay turn on/off light, timer run, scene edit and music play function.
- In accordance with DALI standard protocol IEC 62386-101, 102, 207, 208, 209, and in compliance with DALI products from other international incorporation.
- Enable to select DALI address by encoding switch, support unicast, group and broadcast mode.
- For RGB/RGBW/RGB+CCT light type, built in 10 dynamic mode, include jump or gradual change style.
- Connect with external push switch to achieve on/off and 0-100% dimming function.
- Match with RF 2.4G single zone or multiple zone remote control optional.



**CE RoHS**

### Technical Parameters

Input and Output		Environment		Safety and EMC	
Input voltage	100-240VAC	Operation temperature	Ta: -20°C ~ +55°C	EMC standard	EN IEC 55015/EN IEC 61547 ETSI EN 301 489-1/-3/-17
Input Current	0.1A	Case temperature (Max.)	Tc: +75°C	Safety standard	EN 60669-1/-2
Output voltage	16VDC	IP rating	IP20	Radio Equipment	ETSI EN 300 440 ETSI EN 300 328
DALI output current	Max 150mA	<b>Package</b>		Certification	CE RoHS
Input signal	WiFi + Push switch + RF 2.4GHz	Size	L156x W48x H22mm	<b>Warranty</b>	
Output signal	DALI	Gross weight	0.085kg	Warranty	5 years
Control distance	30m(Barrier-free space)				

### Mechanical Structures and Installations

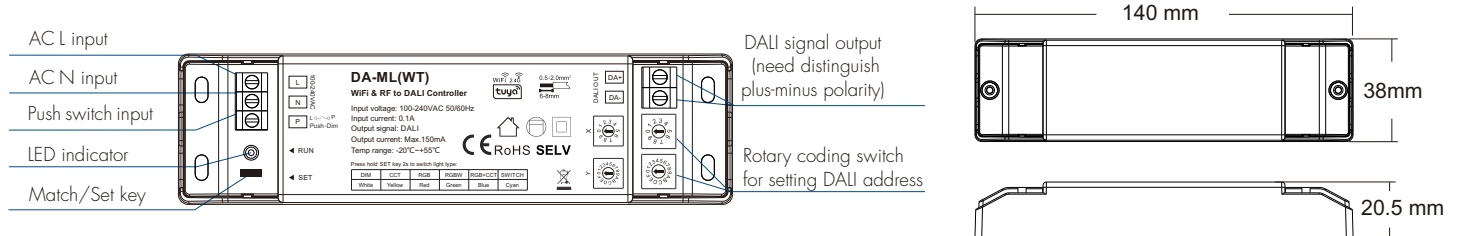

### System Wiring

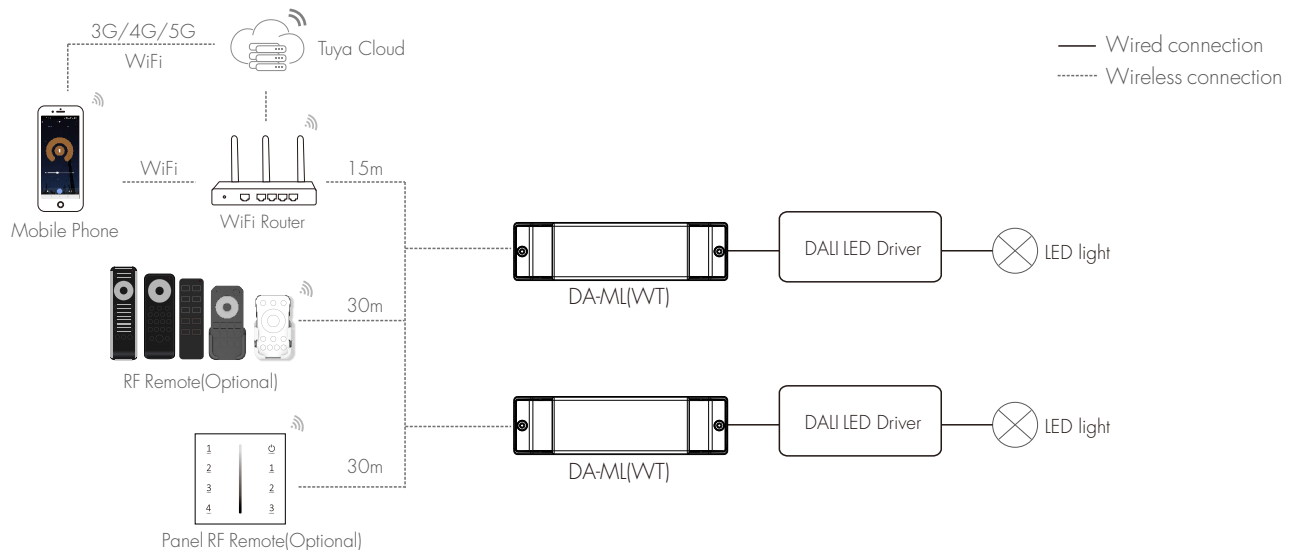

Note:

1. The above distance is measured in spacious (no obstacle) environment, Please refer to the actual test distance before installation.
2. Please check if the WiFi router net in 2.4G band, the 5G band is not available, and do not hide your router network.
3. Please keep the distance between DA-ML(WT) devices and router close, and check the WiFi signals.
4. WiFi signal strength detection: open the main interface of social security, click enter the device interface, click "check device network" for testing.

- DA-ML(WT) as WiFi & RF-DALI master:

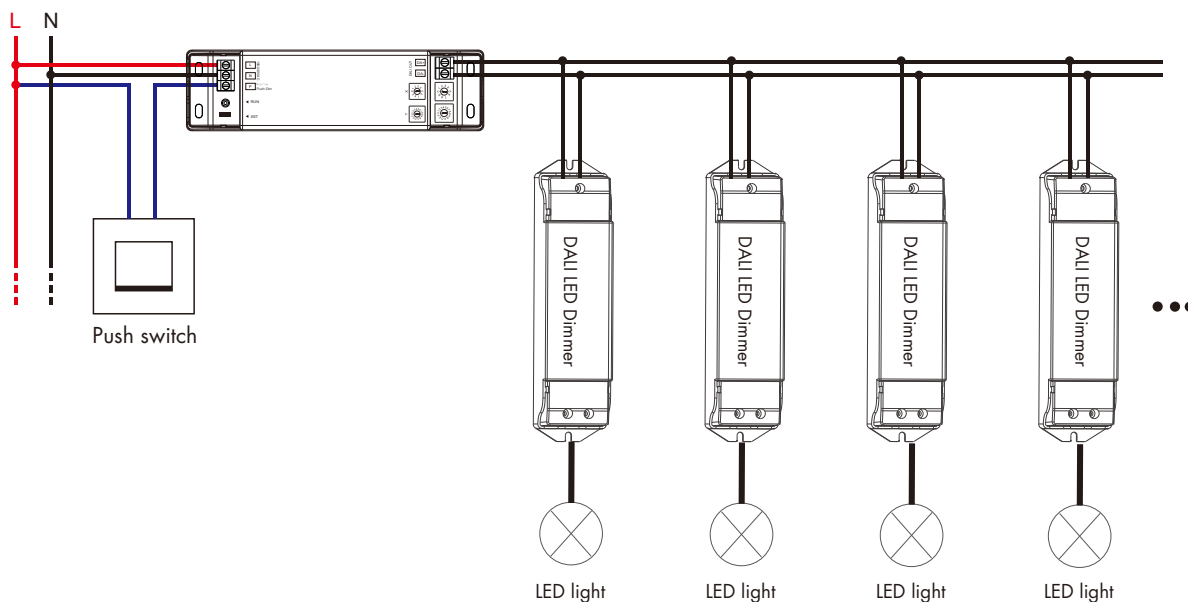

- DA-ML(WT) as DALI bus power supply:

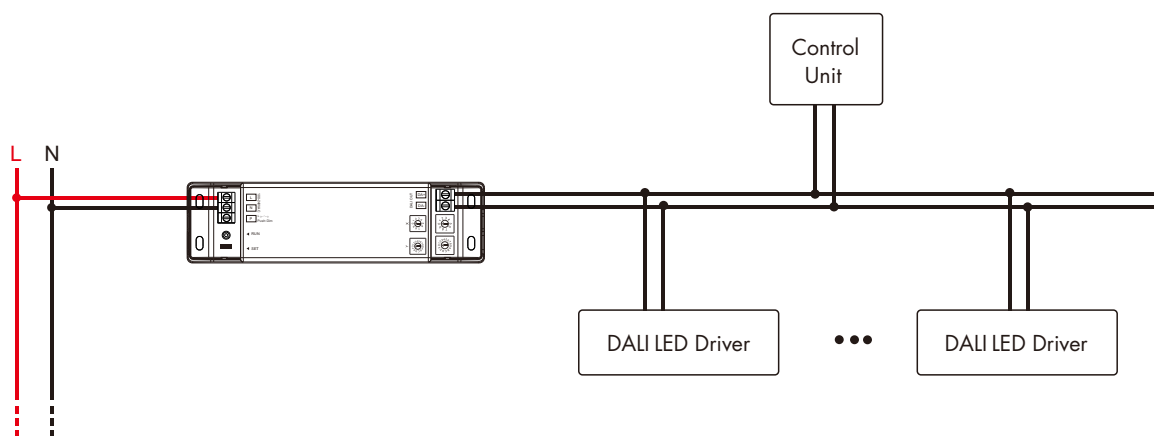

DALI LED driver: include DALI dimming controller, DALI dimming driver, etc.

Control Unit: include DALI master, self-resetting switch, DALI switch panel, DALI sensor, etc.

## Push Dim Function

Short press : Turn on or off light.

Long press 1-6s : Step-less dimming, with every other long press, the light level goes to the opposite direction.

## Light Type Settings

Please select the light type before Tuya smart APP network connection config.

Press and hold Match/Set key for 2s, switch 6 kinds light type in sequence, and LED indicator turn corresponding color.

Light type	DIM	CCT	RGB	RGBW	RGB+CCT	SWITCH
LED indicator color	White	Yellow	Red	Green	Blue	Cyan

Please select the same light type of RF remote control for matching,  
End user can choose the suitable match/delete ways. Two options are offered for selection:

### Use the Match key

Match:

Short press match key, immediately press on/off key (single zone remote) or zone key (multiple zone remote) on the remote.

The LED indicator fast flash a few times means match is successful.

Delete:

Press and hold match key for 5s to delete all match,

The LED indicator fast flash a few times means all matched remotes were deleted.

### Use Power Restart

Match:

Switch off the power of the receiver, then switch on power, repeat again.

Immediately short press on/off key (single zone remote)

or zone key (multiple zone remote) 3 times on the remote.

The LED indicator blinks 3 times means match is successful.

Delete:

Switch off the power of the receiver, then switch on power, repeat again.

Immediately short press on/off key (single zone remote)

or zone key (multiple zone remote) 5 times on the remote.

The LED indicator blinks 5 times means all matched remotes were deleted.

## Dynamic Change Mode List

Ten built-in dynamic modes can be called up with the remote control's mode button.

For RGB/RGBW:

No.	Name	No.	Name
1	RGB jump	6	RGB fade in and out
2	RGB smooth	7	Red fade in and out
3	6 color jump	8	Green fade in and out
4	6 color smooth	9	Blue fade in and out
5	Yellow cyan purple smooth	10	White fade in and out

For RGB+CCT:

No.	Name	No.	Name
1	RGB jump	6	RGB fade in and out
2	RGB smooth	7	Red fade in and out
3	6 color jump	8	Green fade in and out
4	6 color smooth	9	Blue fade in and out
5	Color temperature smooth	10	White fade in and out

## DALI Address Setting

Address value = X \* 10 + Y.

For example: X = 5, Y = 4, Address value = 5 x 10 + 4 = 54.

Unicast mode

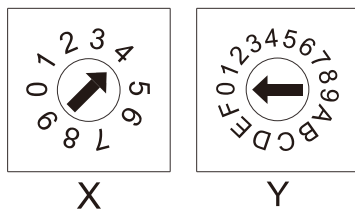

X is 0-6, Y is 0-9.

Address value 0-63 correspond to DALI unicast address 00-63.

For example:

Address value = 40, the unicast address value is 40.

Group mode

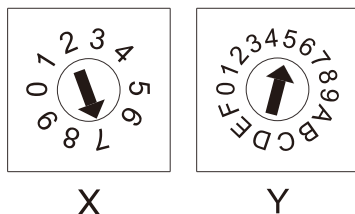

X is 7, Y is 0-F.

Address value 70-7F correspond to DALI group address 0-15.

For example:

Address value = 75, the group address value is 5.

Broadcast mode

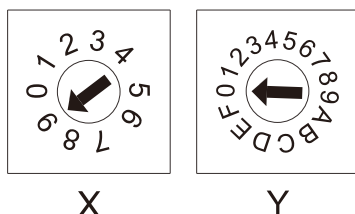

X is 9, Y is 0-F.

Address value 90 - 9F correspond to broadcast address.

● Download and open APP

Search for "Tuya Smart/Smart Life APP" in the app store, or scan the QR code on the right to download the APP. Register and login after installation.

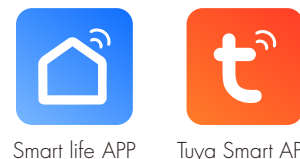

● APP Pairing Network

Two methods to clear the previous network connection, enter WiFi config mode, the LED indicator flash fastly.

1. Push twice Match/Set key fastly.
2. Dimmer power on and off for 5 consecutive times.

Press and hold Match/Set key for 5s: Clear previous network connection, enter WiFi config mode, the LED indicator flash slowly.

If Tuya smart APP network connection succeed, the LED indicator stops flash. And in Tuya smart APP, you can find DIM device (or CCT, RGB, RGBW, RGB+CCT, SWITCH device).

When controlling the light with Tuya Smart/Smart Life APP, if the network connection is poor, you can control the light with Bluetooth connection within the Bluetooth control range.

Note: The light can not be directly controlled by Bluetooth without WiFi configuration.

Tuya Smart APP Interface



Switch Interface

For Switch type:  
Touch the switch key turn on or off light.

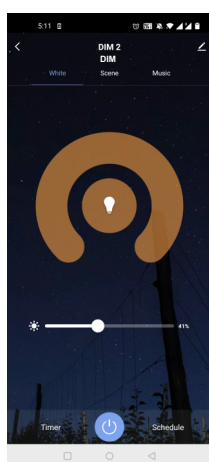

White interface

For DIM type:  
Touch brightness slide to adjust brightness.

For RGB type:  
Touch brightness slide, get RGB mixed white firstly, then to adjust white brightness.

For RGBW type:  
Touch brightness slide, adjust white channel brightness.

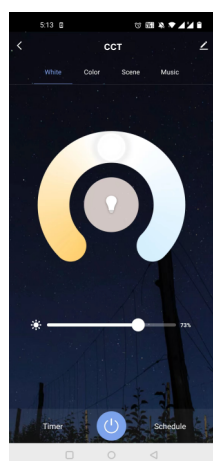

Color temperature interface

For CCT type:  
Touch color wheel to adjust color temperature.  
Touch brightness slide to adjust brightness.

For RGB+CCT type:  
Touch color wheel to adjust color temperature, RGB will turn off automatically.  
Touch brightness slide to adjust white brightness.

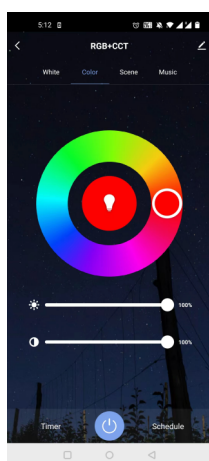

Colour interface

For RGB or RGBW type:  
Touch color wheel to adjust static RGB color.  
Touch brightness slide to adjust color brightness.  
Touch saturation slide to adjust color saturation, namely gradient from the current color to white(RGB mixed).

For RGB+CCT type:  
Touch color wheel to adjust static RGB color, CCT will turn off automatically.  
Touch brightness slide to adjust color brightness.  
Touch saturation slide to adjust color saturation, namely gradient from the current color to white (RGB mixed)

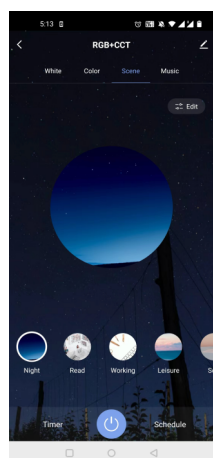

Scene interface

The 1-4 scene is static color for all light type. the inner color of these scene can be editable.  
The 5-8 scene is dynamic mode for RGB type, such as green fade in and fade out, RGB jump, 6 color jump, 6 color smooth.

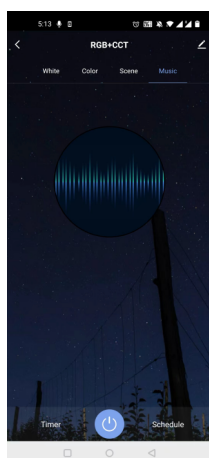

Music, Timer, Schedule

The music play can use smart phone music player or micro-phone as music signal input.  
The Timer key can turn on or turn off light in the next 24 hours.  
The Schedule key can add multiple timers to turn on or turn off light according to different time periods.