

T2-L

0/1-10V

Touch Panel 0/1-10V CCT Dimmer

- Touch panel RF 0/1-10V dimmer, output 2 channel 0/1-10V signal for CCT dimming.
- The two channel output can be set as warm white and cool white dimming respectively, or one for brightness adjust and the other for color temperature adjust.
- 0-10V or 1-10V output selectable by DIP switch.
- 256 levels 0-100% dimming smoothly without any flash.
- Compatibility with RF 2.4G single zone or multiple zone CCT remote control.
- Ultra sensitive high strength glass touch panel with touch color slide.
- Smooth and accurate color adjustment by touching the color slide.
- Touch keys with LED indicator.
- White & Black glass panel available.



CE RoHS RED

Technical Parameters

Input and Output		Dimming data		Safety and EMC	
Input voltage	AC100-240V	Input signal	Touch key + RF 2.4GHz	EMC standard	ETSI EN 301 489-1 V2.2.3 ETSI EN 301 489-17 V3.2.4
Output signal	2 x 0/1-10V	RF Control distance	10m(Barrier-free space)	Safety standard	EN 61347-1:2015+A1:2021 EN 61347-2-13:2014+A1:2017
Output current	2CH, 20mA/CH	Dimming level	256 levels	Radio Equipment	ETSI EN 300 328 V2.2.2
Environment		Dimming range	0 -100%	Certification	CE RED
Operation temperature	Ta: -20°C ~ +55°C	Package		Warranty	5 years
Case temperature (Max.)	Tc: +65°C	Size	L112 x W112 x H50mm	Warranty	5 years
IP rating	IP20	Gross weight	0.230kg		

Mechanical Structures and Installations

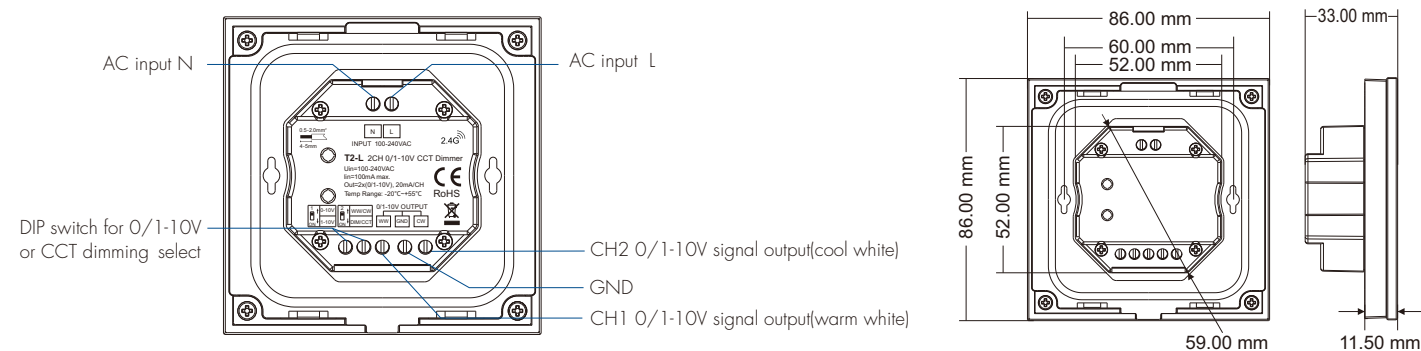

Installation diagram:

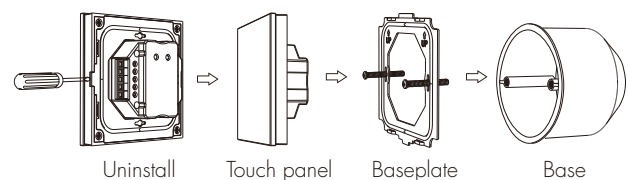

Typical base as below:

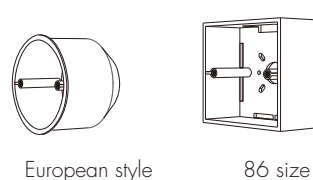

Key Function

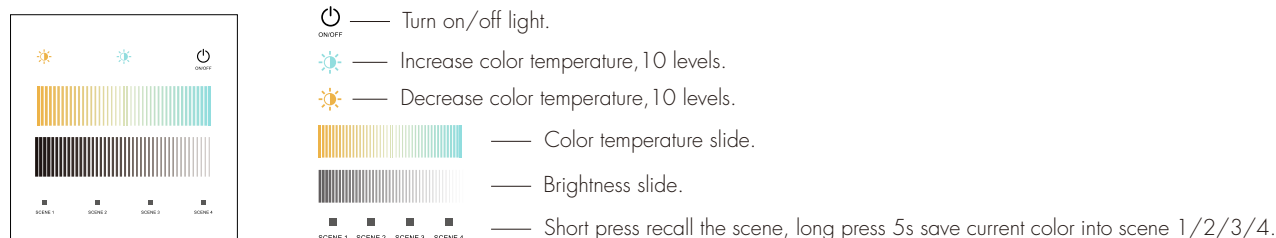

Scene locking:

- Scene keys can be set to locked state, cancel long press for 5 seconds to save the scene function (default scene is not locked).
- Short press the panel on/off key, turn on the light first, then turn off the light, immediately long press the panel on/off key for 5 seconds, then immediately long press any one scene key for 5 seconds to set all scene keys to locked state.
- Short press the panel on/off key, turn on the light first, then turn off the light, immediately long press the panel on/off key for 5 seconds, then immediately long press any one scene key for 10 seconds to restore all scene keys to unlocked state.

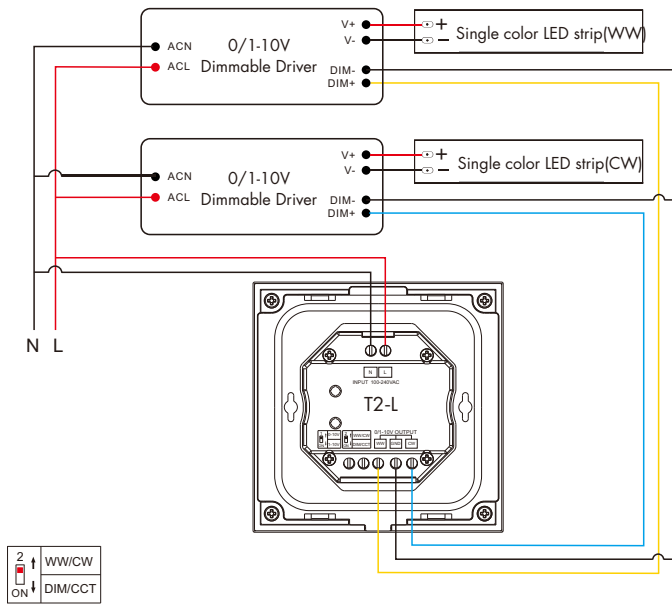

Select the DIP switch 2 OFF, set as CH1 for warm white dimming and CH2 for cool white dimming respectively.

Note:

We recommend the number of LED drivers connected to 0/1-10V dimmer does not exceed 50 pieces, The maximum length of the wires from dimmer to LED driver should be no more than 50 meters.

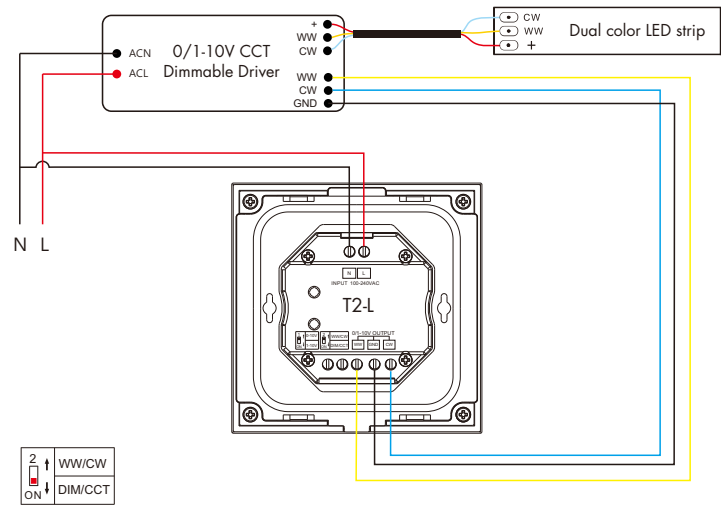

Select the DIP switch 2 ON, set as CH1 for brightness adjust and CH2 for color temperature adjust.

Match Remote Control (Two Match Ways)

The 0-10V touch panel dimmer can also match with the RF remote (optional). End user can choose the suitable match/delete ways. Two options are offered for selection:

Use On/Off key

Match:
Turn on light, turn off, immediately press the On/Off key of the panel for 5s, then press on/off key(single zone remote) or zone key(multiple zone remote) of the RF remote within 5s. The LED indicator fast flash 3 times means match is successful.

Delete:
Turn on light, turn off, immediately press the On/Off key of the panel for 10s to delete all match, The LED indicator fast flash 6 times means all matched remotes were deleted.

Use Power Restart

Match:
Switch off the power, then switch on power, repeat again, Immediately short press on/off key (single zone remote) or zone key (multiple zone remote) 3 times on the remote. The light blinks 3 times means match is successful.

Delete:
Switch off the power, then switch on power, repeat again, Immediately short press on/off key (single zone remote) or zone key (multiple zone remote) 5 times on the remote. The light blinks 5 times means all matched remotes were deleted.

0-10V or 1-10V Dimming Setting

Select 0-10V dimmer or 1-10V dimmer according to dimmable LED driver.

